

Teleline™

Wall-Mount Power Supply Chassis model 750003 Description and Installation

925W751051-02E



Contents

Chapter 1 – General Information

1.1 Publication Information	6
1.2 About this Guide	7
Related Documentation	7
Positron Products and Services	7
1.3 Service and Support	8
Technical Customer Support	8
Customer Training	8
Repair Service	9
1.4 Teleline Warranty	10
Limitation of Liability	10
Cancellation and Rescheduling Charges	11

Chapter 2 – Overview

2.1 Introduction	14
2.2 Description	16
Input/Output terminal block	16
Power Supply/Battery Back-up terminal block	18
Input fuse	18
Ground lug	18
Ground jumper setting	19
2.3 Specifications	20

Chapter 3 – Installation

3.1 Installation	22
3.2 Chassis Mounting	22
3.3 Earthing Connector	24

3.4 Input Power Connections	25
3.5 Chassis Wiring	25
24 V systems	25
48 V systems	26
Adding redundancy	27
Adding Battery Back-up to a 24 V system	30
Adding Battery Back-up to a 48 V system	30

Appendix A – Acronyms

Acronyms	34
----------------	----

Chapter 1

General Information

1.1 Publication Information

© 2012 Positron Inc.

Wall-Mount Power Supply Chassis model 750003

Description and Installation Guide

Part number: 925W751051-02E

Publication date:

May 1, 2012

Published By

Positron Inc.

5101 Buchan Street, Suite 220

Montreal, Quebec, Canada

H4P 2R9

Telephone: US and Canada: 1-888-577-5254

International: 1-514-345-2220

Trademarks

Teleline is a trademark of Positron Inc.

Product names, other than Positron's, mentioned herein may be trademarks and/or registered trademarks of their respective companies

Confidentiality Notice

The information contained in this document is the property of Positron Inc. Except as specifically authorized in writing by Positron Inc., the holder of this document: 1) shall keep all information contained herein confidential and shall protect same in whole or in part from the disclosure and dissemination to all third parties, and 2) shall use same for operating and maintenance purposes only.

Disclaimer Notice

Although Positron Inc. has made every effort to ensure the accuracy of the information contained herein, this document is subject to change without notice.

1.2 About this Guide

This guide introduces you to the Wall-Mount Power Supply Chassis model 750003, its features and applications, and describes how to install it. This guide was designed to be read from beginning to end.

1.2.1 Related Documentation

The other guides in the Teleline set are listed below. To order any manuals, please contact your customer service representative.

- Teleline System Manual
- Teleline System Overview
- Teleline Product Guide

1.2.2 Positron Products and Services

Positron engineers and manufactures high voltage isolation products to protect personnel and telecommunications circuits in high voltage areas that are susceptible to the effects of Ground Potential Rise (GPR).

Positron is the leader in isolation technology with its Teleline wireline products and TeleLite optical fiber wireline isolation/protection product families. Positron provides total flexibility in product configuration – from standalone units protecting a single circuit to high-capacity, multi-shelf HVI preconfigured systems.

Positron also provides a wide range of consulting, analysis and training services for communications companies and electrical utilities.

Full details and contact information are available at www.PositronPower.com.

1.3 Service and Support

Table 1: Positron Contact Information

General information:	Positron Inc. 5101 Buchan Street, Suite 220 Montreal, Quebec, Canada H4P 2R9 US and Canada: 1-888-577-5254 International: 1-514-345-2220 Fax: 514-345-2271 E-mail: info@positronpower.com Website: www.PositronPower.com
Customer Service and Repairs:	US and Canada: 1-888-577-5254 International: 1-514-345-2220 E-mail: customerservice@positronpower.com

1.3.1 Technical Customer Support

Positron is committed to providing excellent ongoing technical support to its customers. A team of specialists is always available for telephone consultations or for on-site visits to assist in the maintenance and troubleshooting of Positron equipment.

For pricing information or assistance in the planning, configuration and implementation of the installation of equipment, contact Technical Customer Service.

1.3.2 Customer Training

Full customer training courses on High Voltage Interface (HVI) are also available. For more information, contact Positron.

1.3.3 Repair Service

All warranty repairs are performed at no cost. Positron reserves the right to repair or replace any equipment that has been found to be defective.

For information about out-of-warranty repairs, contact Positron's Repair Department. Due to the varied nature of repairs, no specific turnaround can be guaranteed, but average turnaround time is 20 working days from date of receipt. In emergency situations, special arrangements can be made. All repaired items are warranted for a period of 90 days.

Before returning any items to Positron for repair, warranty repair or replacement, call the Repair department to obtain a Return Material Authorization (RMA) number. Parts returned without RMA numbers cannot be accepted. The RMA number must always be clearly marked on all boxes, crates, and shipping documents. Bulk repairs (more than five items) will require additional processing time, so please take this into consideration when requesting an RMA number.

To accelerate the repair process, whenever possible, include a report detailing the reason for return with the unit(s). Also, please include the name and phone number of a person who can be contacted should our Repair department need further information.

When packing items being returned for repair, please ensure they are properly packed to avoid further damage. TeleLite plug-in cards should never be shipped while installed in a shelf; this will cause damage that can extend the repair period.

1.4 Teleline Warranty

Subject to the provisions of this paragraph, Positron warrants that the equipment shall perform in accordance with Positron's specifications. The warranty remains valid for five (5) years from the date of shipment. The warranty fully covers workmanship, materials and labor. Positron shall, at its sole discretion, repair or replace the problem unit.

Freight costs to ship defective equipment to Positron are borne by the Customer, with return of replaced or repaired equipment to be at Positron's expense.

1.4.1 Limitation of Liability

Subject to anything to the contrary contained herein, Positron's sole obligation and liability and the customer's sole remedy for Positron's negligence, breach of warranty, breach of contract or for any other liability in any way connected with or arising out of, the equipment or any services performed by Positron shall be as follows:

- In all situations involving performance or non-performance of the equipment or any component thereof, the customer's sole remedy shall be, at Positron's option, the repair or replacement of the equipment or said component.
- For any other claim in any other way related to the subject matter of any order under, the customer shall be entitled to recover actual and direct damages; provided that Positron's liability for damages for any cause whatsoever, and regardless of the form of the action, whether in contract or in tort (including negligence), shall be limited to the value of the order.

Positron shall not be obligated to repair or replace any item of the equipment which has been repaired by others, abused or improperly handled, improperly stored, altered or used with third party material or equipment, which material, or equipment may be defective, of poor quality or incompatible with the equipment supplied by Positron, and Positron shall not be obligated to repair or replace any component of the equipment which has not been installed according to Positron specifications.

IN NO EVENT SHALL POSITRON BE LIABLE FOR ANY INDIRECT, INCIDENTAL, SPECIAL, CONSEQUENTIAL, PUNITIVE, EXEMPLARY OR SIMILAR OR ADDITIONAL DAMAGES INCURRED OR SUFFERED INCLUDING

LOSS OF PROFITS, LOSS OF REVENUES, LOSS OF DATA, LOSS OF BUSINESS INFORMATION, LOSS OF GOODWILL, LOSS OF EXPECTED SAVINGS OR BUSINESS INTERRUPTION ARISING OUT OF OR IN CONNECTION WITH THE EQUIPMENT, A PURCHASE ORDER, SUPPLIES, MAINTENANCE SERVICES OR OTHER SERVICES FURNISHED HEREUNDER, EVEN IF POSITRON HAS BEEN ADVISED OR IS AWARE OF THE POSSIBILITY OF SUCH DAMAGES.

EXCEPT AS EXPRESSLY SET FORTH IN THIS AGREEMENT, POSITRON DISCLAIMS ANY FURTHER CONDITIONS, REPRESENTATIONS OR WARRANTIES, WHETHER WRITTEN OR ORAL, EXPRESSED OR IMPLIED, INCLUDING THE CONDITIONS AND WARRANTIES OF MERCHANTABILITY, MERCHANTABILITY QUALITY, FITNESS FOR A PARTICULAR PURPOSE, TITLE, PERFORMANCE AND THOSE ARISING FROM STATUTE, TO THE EXTENT PERMITTED BY LAW. POSITRON DOES NOT WARRANT THAT THE SYSTEM WILL OPERATE WITHOUT INTERRUPTION OR THAT IT WILL BE ERROR FREE.

1.4.2 Cancellation and Rescheduling Charges

Should the customer cancel, prior to shipment, any part of an order, the customer agrees to pay to Positron cancellation charges, not as a penalty, which shall total all expenses, including labor expenses, incurred by Positron prior to said cancellation. Equipment that has been specially developed for the customer's specific applications shall not be subject to cancellation. Cancellation or rescheduling is not permissible after shipment of the System.

Chapter 2

Overview

2.1 Introduction

The Wall-Mount Power Supply Chassis provides a means to use any of the Teleline Power Supplies (751313MC, 751316, 751318MC, 751319MC, 751324) or Battery Backup Module (751312) outside of the Teleline Shelves. The Chassis mounts either flat on a wall or perpendicular to the wall to save space. Multiple modules can be used to provide redundancy or backup. The Chassis has an input/output terminal block and a battery backup terminal block to connect other Chassis to it. The Chassis is equipped with spring-loaded locking mechanisms to prevent cards from dislodging due to vibration.

The Wall-Mount Chassis allows the user to configure the output to floating (24 Vdc/48 Vdc), negative voltage (-24 Vdc/-48 Vdc) or positive voltage (+24 Vdc/+48 Vdc) through a jumper setting (W1) located on the backplane of the Chassis.

- The default setting is for -24 Vdc/-48 Vdc.

For a view of the Power Supply Chassis, see Figure 1 on page 15.

For a view of the jumper W1, refer to Figure 3 on page 19.

Figure 1: Wall-Mount Chassis

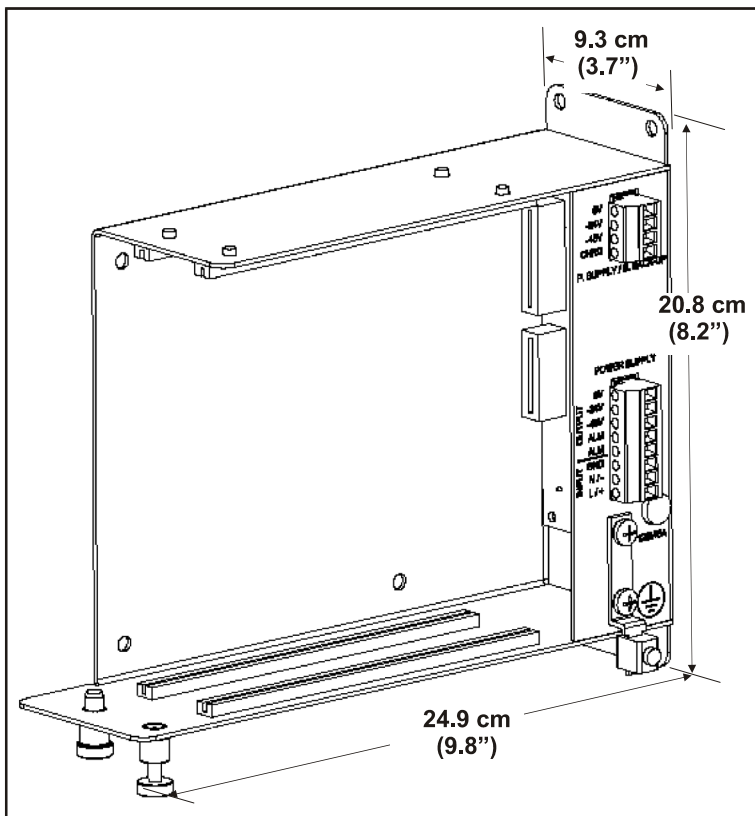
**NOTE**

- The fuse is a FAST, 5A/125V, 3AG type fuse.

2.2 Description

Below is a description of the Chassis. For a view of the detailed section, please refer to Figure 1 on page 15.

2.2.1 Input/Output terminal block

Input power is brought to the Chassis through the bottom three contacts of the terminal block. Depending on the Power Supply being used, it can be fed either 120 Vac, 130 Vdc, 48 Vdc or 24 Vdc. Although the Power Supply Modules are not polarity-sensitive, the power has to be wired according to the polarity indications on the terminal blocks.

The output from the Power Supply comes out of the top three pins of the terminal block. The top contact is the positive lead, the second contact provides the negative lead of a 24 V power output and the third contact provides the negative lead of a 48 V power output.

The fourth and fifth output pins provide alarm contacts. Whenever the output of a Power Supply fails, the alarm contact on the unit will close, these alarm contacts are provided through these two pins. When two Power Supplies are used with two Power Supply Chassis, the alarm contacts of each of the Chassis can be wired in parallel or separately to provide an alarm for the system or each Chassis. If one unit fails, then an alarm is raised while the second unit still provides power to the system.

For a view of the terminal block, refer to Figure 2 on page 17 and Table 2 on page 18.

Figure 2: Wall-Mount Chassis Terminal Block View

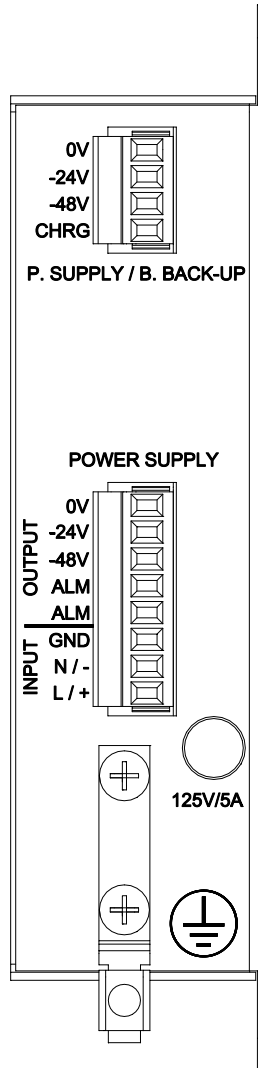

2.2.2 Power Supply/Battery Back-up terminal block

This terminal block provides charging power to a second Chassis used to house a Battery Back-up Module 751312.

When a second Chassis is used to provide redundancy, its output will be connected to this terminal block on the primary Chassis.

It is also possible to provide 48 V battery back-up using two 751312 units by wiring the output accordingly. See section 3.5 on page 25 for more information. For a view of the terminal block, refer to Figure 2 on page 17 and Table 2 on page 18.

2.2.3 Input fuse

The input fuse is connected in series with the Live lead of the input power feeding the Chassis to provide overcurrent protection in case of damaging surges or failure of the Power Supply Module. The fuse is a FAST, 5A/125V, 3AG type fuse and must be replaced with the same type of fuse.

2.2.4 Ground lug

The Chassis must be grounded through the ground lug to a solid local ground using a #10 AWG or bigger, wire.

Table 2: Input/Output Terminal Block pinout

Function		
OUTPUTS:	0V	Positive output of 24 V/48 V
	-24 V	Negative output of 24 V
	-48 V	Negative output of 48 V
	ALM	Normally open relay contact provides dry contact closure for an audio or visual indication of an output power failure.
	ALM	
INPUTS:	GND	Input cable ground wire
	N/-	Power input Neutral wire (for AC input) or negative wire (for DC input)
	L/+	Power input Live wire (for AC input) or positive wire (for DC input)

Table 3: Power Supply/Battery Back-up Terminal Block pinout

	Function
0 V	Positive voltage to/from battery back-up or redundant power supply Chassis
-24 V	Negative of 24 V to/from battery back-up or redundant power supply Chassis
-48 V	Negative of 48 V from battery back-up or redundant power supply Chassis
CHRG	Negative of 48 V to battery back-up Chassis

2.2.5 Ground jumper setting

The backplane of the Wall-Mount Chassis is equipped with a jumper setting, W1, that allows the output to be configured as floating, negative voltage or positive voltage referenced to ground. The unit is set at the factory to provide negative voltages (-24 Vdc/-48 Vdc) for Teleline/TeleLite installations.

The configurations are well indicated on the backplane at the different locations where W1 can be installed.

- For a view of the jumper W1, see Figure 3 on page 19.

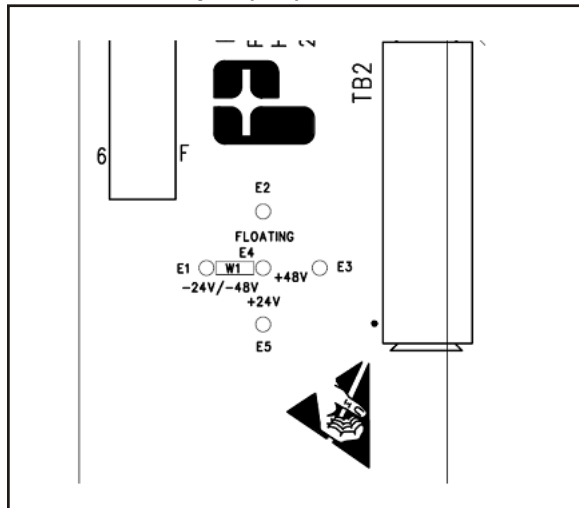
Figure 3: Ground Jumper (W1)

2.3 Specifications

Table 4: Physical Specifications

	Specification
Weight	1 kg (2.3 lbs.)
When installed flat against the wall	
Height	20.8 cm (8.2")
Width	24.9 cm (9.8")
Required space at left of Chassis to insert modules	17.7 cm (7.0")
Depth	9.3 cm (3.7")
When installed perpendicular to the wall	
Height	20.8 cm (8.2")
Width	9.3 cm (3.7")
Required space at right of Chassis for connections	8.9 cm (3.5")
Depth	24.9 cm (9.8")

Table 5: Environmental Specifications

Parameter	Specification
Operating temperature	-40°C to +85°C (-40°F to 185°F) **Will be limited by operating temperature of Power Module inserted in Chassis.
Storage temperature	-40°C to +85°C (-40°F to 185°F)
Humidity (non-condensing)	20% to 80%
Altitude	-61m to 3048m (-200ft to 10,000ft) above sea level

Table 6: Electrical Specifications

Parameter	Specification
Maximum input current	5 A
Maximum output current	5 A
Alarm contact rating	2 A@30 Vdc, 0.5 A@125 Vac, 10 ⁵ operations

Chapter 3

Installation

3.1 Installation

Installations should conform to local practices and electrical code regulations. The equipment must be installed in restricted or secure area to prevent tampering.

 <p>ATTENTION ELECTROSTATIC SENSITIVE DEVICES HANDLE ONLY AT STATIC SAFE WORKSTATION</p>	<p>ESD Precaution INCORRECT HANDLING MAY VOID WARRANTY</p> <p>These procedures must be followed when handling an electrostatic sensitive device.</p> <ul style="list-style-type: none">• A grounded wrist strap must be worn at all times during installation.• When unpacking, place the antistatic bag containing the device on an electrostatic discharge (ESD) safe surface. An ESD safe surface is a conductive surface connected directly to an earth ground.• When moving, carry the device in an ESD safe container or the antistatic bag, provided with the device.
--	--

3.2 Chassis Mounting

The Wall-Mount Chassis Model 750003, must be installed indoors, close to the equipment it is going to power. Power will need to be routed to the Chassis. The Chassis can be mounted in two different orientations, either flat against the wall or perpendicular to the wall where the space is limited.

► **To install the Wall-Mount Chassis:**

1. Verify that you have the following customer-provided tools and hardware required to install the Chassis:
 - Phillips screwdriver
 - 2 cm (3/4") or 2.5 cm (1") thick plywood backboard and appropriate mounting hardware
 - Cable clamps and mounting hardware for routing cables exterior to the shelf (quantity determined by the cable lengths).
 - Black and Red wires, stranded, #18-#14 AWG (lengths determined by number of Chassis and distance to equipment to be powered)
2. Unpack the Wall-Mount Chassis Model 750003 and its hardware from its box.
3. To mount the Chassis, install the plywood backboard on the wall to provide a secure mounting surface.
4. Place the Chassis in the desired location and orientation on the backboard and mark the location of the four mounting holes.
5. Mount the Chassis using the screws supplied in the kit.
6. If other Chassis are used to provide redundant power supplies, increased power output or battery backup, repeat the above steps for the other Chassis.

3.3 Earthing Connector

CAUTION



To ensure safety of personnel, Positron recommends following these guidelines:

- Each Chassis of an installation must be permanently connected to earth using the ground lug on the front of the Chassis.
- The field wiring should include a readily-accessible disconnect device. The disconnect device shall disconnect both poles (RTN and Live).
- This equipment must be located in the same immediate area (such as adjacent cabinets) as the equipment it is powering.
- There shall be no switching or disconnecting devices in the earthed circuit conductor between any Chassis of an installation and the point of connection of the earthing electrode conductor.

3.4 Input Power Connections

Depending on which Power Supply is plugged-in, the Wall-Mount Chassis can be powered from 24 Vdc, 48 Vdc, 130 Vdc or 120 Vac. The input power is connected to the Chassis through the input terminal block. For a view of the pinout, see Figure 2 on page 17 and Table 2 on page 18.

When powered from AC, the Live wire is connected to the “L” terminal, the neutral wire is connected to the “N” terminal and the power ground is connected to the “GND” terminal. When powered from DC, the “-” terminal will be connected to the negative input lead and the “+” terminal will be connected to the positive lead.

If multiple Chassis are being used, each must have its own power cable. A fuse is provided on the live/positive input lead to provide input overcurrent protection. That fuse must be replaced with the same type and rating. See section 2.1 on page 14 for more information.

3.5 Chassis Wiring

3.5.1 24 V systems

When using 24 V Power Supplies, the Chassis can provide floating 24 Vdc, -24 Vdc or +24 Vdc referenced to ground. Connect the positive output of the Chassis (0 V) to the positive input of the equipment and the negative output of the Chassis (-24 V) to the negative input of the equipment.

- Unit is factory set for -24 Vdc output.

Refer to Figure 4 on page 26 for a view of the 24 V wiring.

Figure 4: 24 V Power supply Source

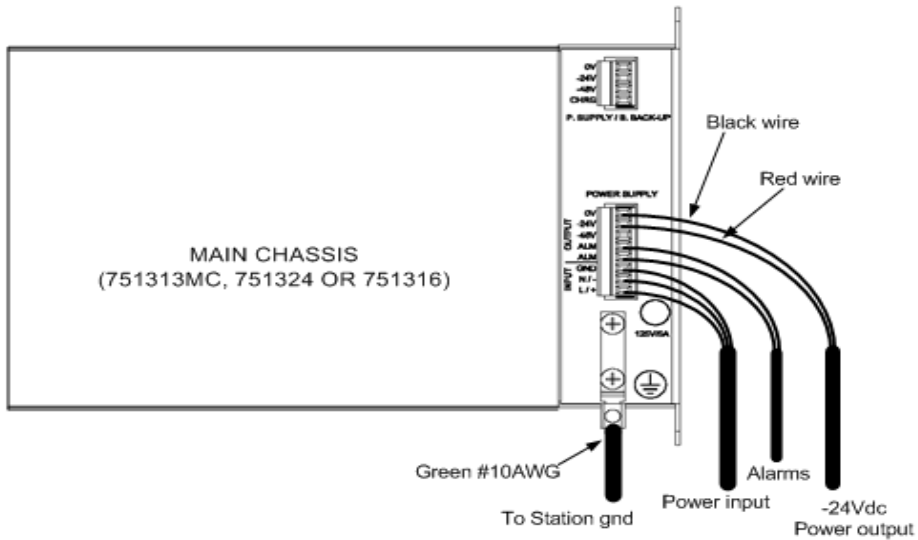

3.5.2 48 V systems

When using 48 V Power Supplies, the Supplies, the Chassis can provide floating 48 Vdc, -48 Vdc or +48 Vdc referenced to ground. Connect the positive output of the Chassis (0 V) to the positive input of the equipment and the negative output of the Chassis (-48 V) to the negative input of the equipment.

- Unit is factory set for -48 Vdc output.

Refer to Figure 5 on page 27 for a view of the 48 V wiring.

Figure 5: 48 V Power Supply Source

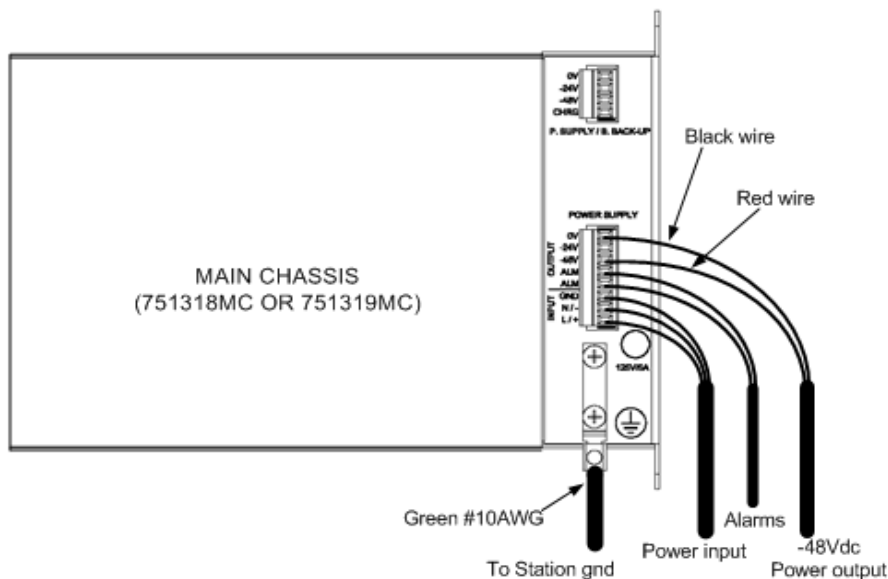

3.5.3 Adding redundancy

A second Chassis and Power Supply can be added to the system to provide a redundant power source. With this system, if one of the Power Supply were to fail, the second Power Supply would take over the load without power interruption. The failing Power Supply would trigger an alarm through its alarm contacts (if used) to let the user know the system needs maintenance.

For such a system, the redundant Chassis would be connected to the Main Chassis as shown in Figure 6 on page 28 and Figure 7 on page 29.

Figure 6: Redundant 24 V Power Supply

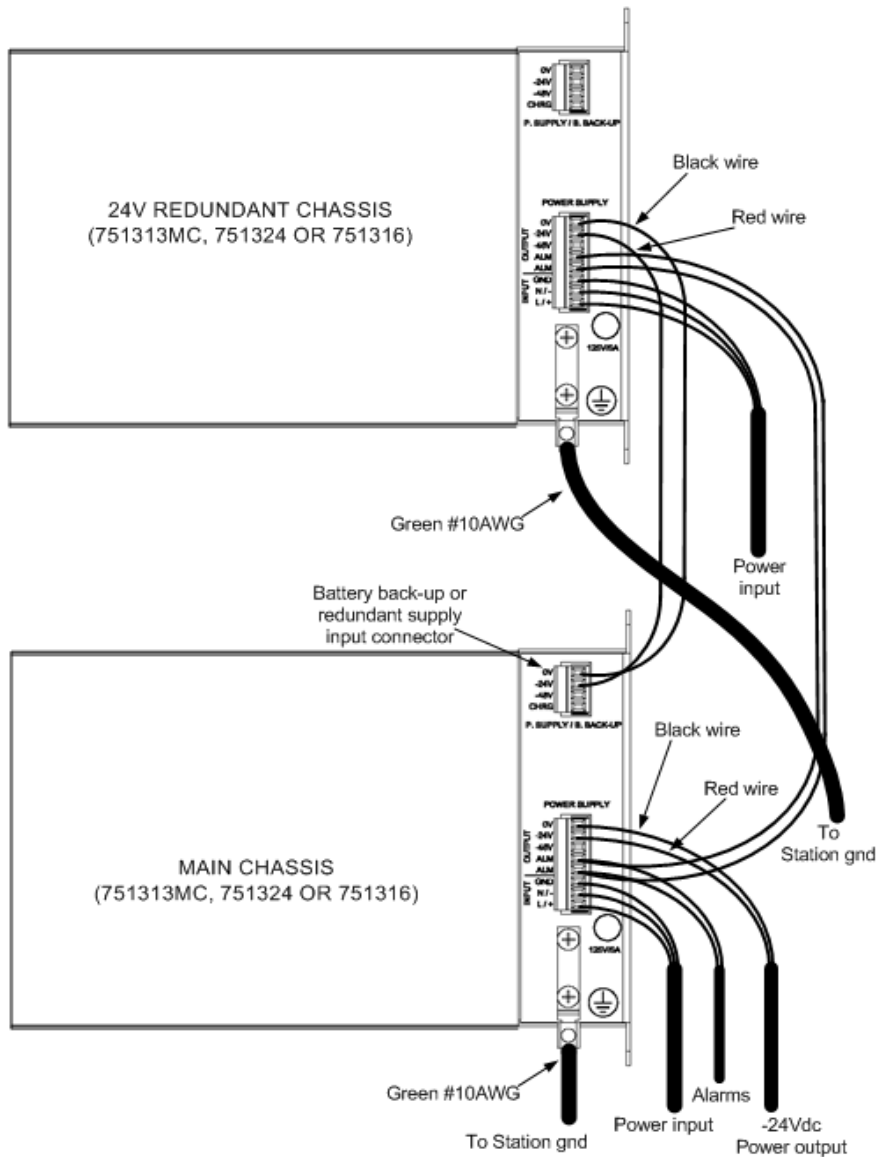

3.5.4 Adding Battery Back-up to a 24 V system

A battery back-up can be added to the system to provide an Uninterruptible Power Supply (UPS).

To accomplish this, a second Chassis containing a 751312 battery pack needs to be added. The second Chassis will be wired as shown in Figure 8 on page 31.

3.5.5 Adding Battery Back-up to a 48 V system

A battery back-up can also be added to a 48 V system to provide an Uninterruptible Power Supply (UPS).

To accomplish this, two Chassis must be added. Each Chassis will contain a 751312 battery pack.

The three Chassis will be wired as shown in Figure 9 on page 32.

Figure 9: Three -48 V Chassis Wired for Battery Backup

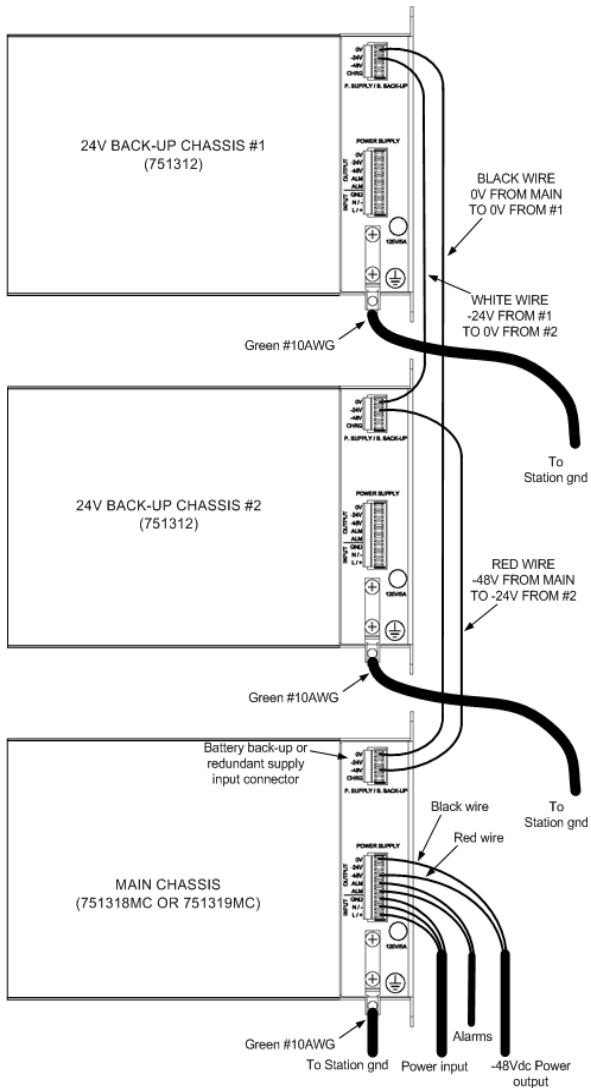

Appendix A

Acronyms

Acronyms

AWG

American Wire Gauge

CO

Central Office

GND

Ground

GPR

Ground Potential Rise

RMA

Return Material Authorization

RMT

Remote

RTN

Return

UPS

Uninterruptible Power Supply